

SEWON METAL

C A T A L O G

LEADER OF HOT FORGING
BEST QUALITY & CUSTOMER SATISFACTION



 SEWON METAL CO.,LTD.

SEWON METAL

NEW TECHNOLOGY WITH WORLD WIDE RECOGNITION.

The company primarily manufactures driving, engine, hydraulic and fuel parts for automobiles including industrial flanges and hot forging parts for engine gears in agricultural machinery in addition to timing chains in ship engines. In particular, SEWON METAL manufactures forging pistons which are key strategic parts. The company is currently in the process of expanding its share in the global market and is being recognized for high quality products and technical skills.

With continued research and development for innovative new technologies and management systems, SEWON METAL is striving to achieve thorough on-site management and zero tolerance for defective products based on the three management principles-sound management, quality management, and customer satisfaction. In addition, the company has made efforts to increase sales through production of products with high added value and competitive edge.

SEWON METAL will provide a better future by creating value and satisfying customer needs-anywhere, anytime. Thank you.

President of SEWON METAL CO., LTD.
Jung-Hee, Lee





HISTORY

- 1995. 11 Established SEWON METAL
- 2000. 06 Transfer to SEWON METAL CO., LTD.
- 2002. 08 Transfer and enlargement of the factory
- 2003. 04 Certified quality system SQ mark by HYUNDAI & KIA MOTOR company
- 2005. 10 Established R&D Center(KOITA)
Registered Venture Company(SMBA)
- 2005. 11 Winning one million dollars export award (KITA)
- 2006. 03 ISO/TS 16949 (IATF)
- 2007. 01 Registered INNO-BIZ company (SMBA)
- 2008. 06 Achived special permission of Piston skirt mold
Certified environmental management systems ISO 14001
- 2012. 04 Certificated DNV, Lloyd's, BV, GL
- 2013. 04 Achieved special permission of Piston skirt mold
- 2013. 09 Install Forging 2,500 ton press with Auto Transfer line
- 2013. 10 Achieved special permission of forging press with vibration isolation structure
- 2014. 12 Winning twenty million dollars export award(KITA)
- 2015. 01 Install Forging 3,500 ton press with Auto robot
- 2015. 04 Appointment of root tech
- 2015. 06 Pre-world calss 300 certificate
- 2015. 11 Received Minister prize - Parts section



Customer-
Satisfaction

Main Facilities

SEWON METAL is creating the value of hot forging parts with strict production process and optimized facilities.



FORGING PROCESS FLOW

1 INPUT OF MATERIAL



2 CUTTING

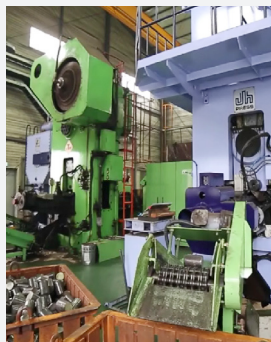

3 HEATING



4 FORGING



5 HEAT TREATMENT & CONTROL COOLING





Description	Size	ea
CUTTING	300T PRESS	1
	600T PRESS	1
	800T PRESS	1
FORGING	750T PRESS	1
	1350T PRESS	4
	1600T PRESS	3
	2500T PRESS	1
	2500T PRESS (TRANSFER)	1
	3000T PRESS	1
MACHINING	3500T PRESS (ROBOT)	1
	MCT BT40	10
	CNC	12
	TAPPING CENTER	3
	INTERNAL GRINDING	4
	TWO WAY BORING	7

6 SHOT BLAST

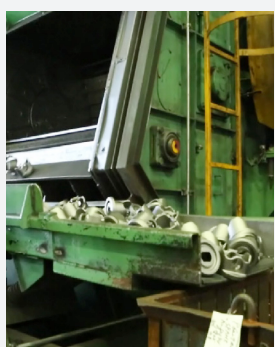

7 MPI



8 MACHINING



9 INSPECTION



10 PACKING, DELIVERY



Auto- motive Parts

We are specialized in semi-finished product in hot forging parts.

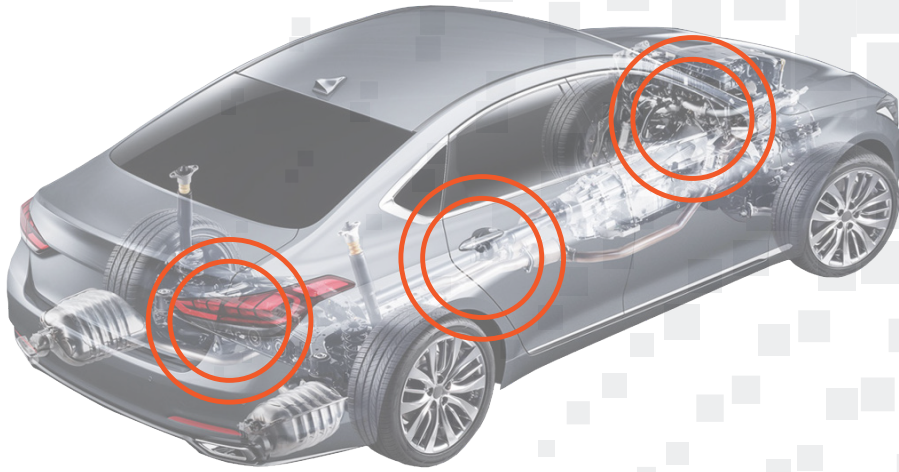

Connecting Rod



Shaft & Sleeve

We export products to USA, Mexico, Singapore, and EU mainly which means we have competitiveness across the world in the field.



Flange Rear



Clutch fork



Engine Piston (LVD)



Hub & Outer Ring

Commercial Vehicle Parts

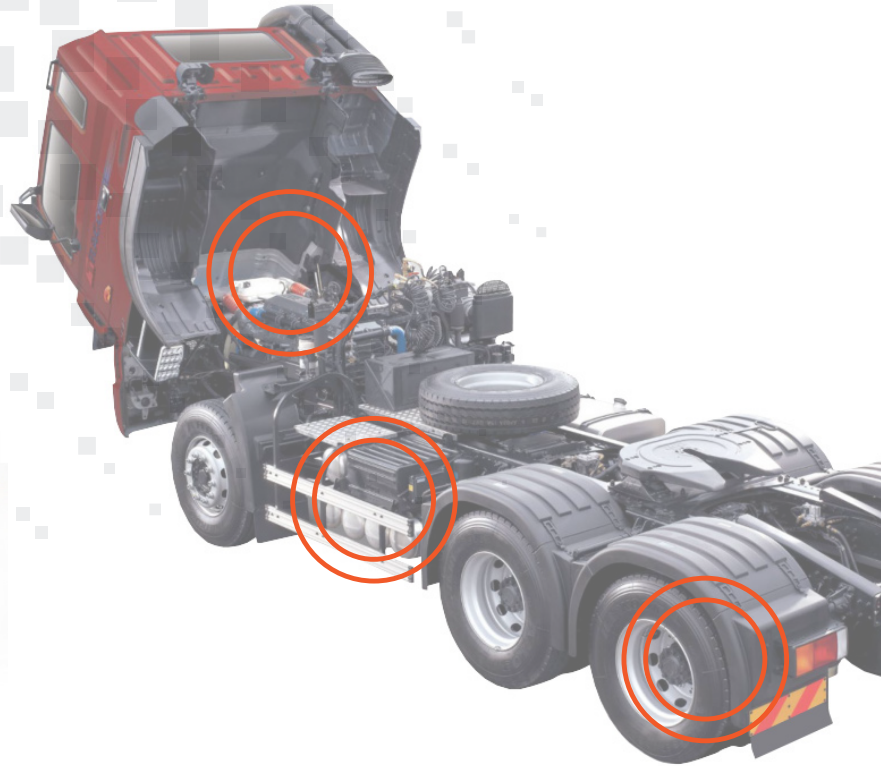

Wavy Piston Top



Propeller Yoke & Shaft



Engine Piston Top & Bottom

We have a competitive edge both price and quality.

We always set quality and price as a first priority in our business to customers.



Rocker Arm



Gear & Sprocket



Wing Bushing

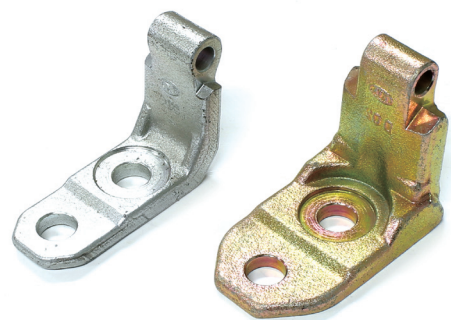

Door Hinge

Heavy Equipment Parts

We produce heavy equipment parts based on a customer satisfaction.

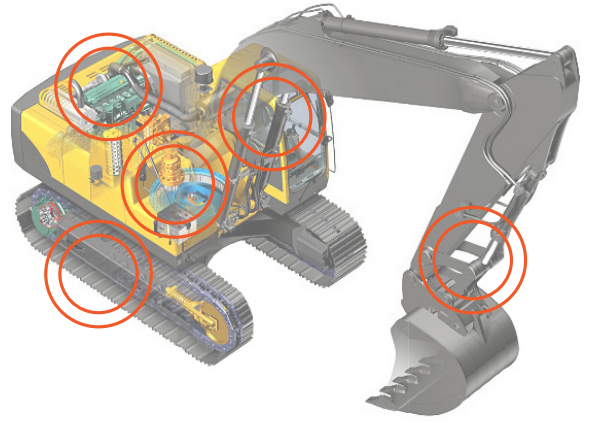

End Rod & Yoke



Joint Yoke & Flange



Gear & Mission Part

Ship / Other Parts

We have shipping certificates such as GL, Lloyd`s DNV, and BV.



Chain for Ship



Industrial Machine Parts

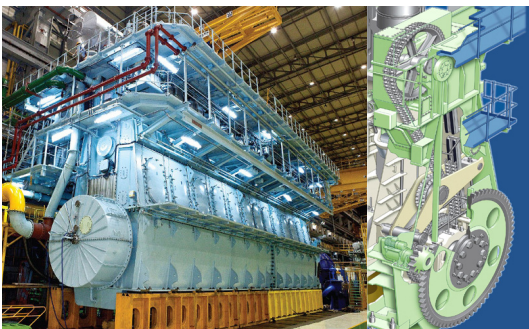

Nipple & Flange



Weight

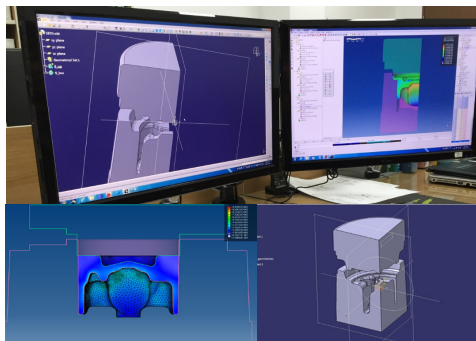

Patents and Certificates



ISO 14001 :2004



OHSAS 18001 :2007



ISO/TS 16949 :2009



Patent for Manufacturing of Steel Piston



Patent for Structure of vibration preventing



Patent for Skirt Mold of Steel Piston



Certificate for Root Tech

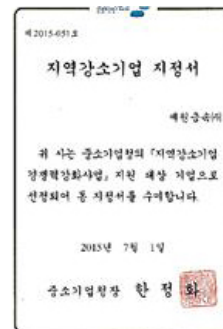

Certificate for Pre-World Class



Certificate for INNO-BIZ

SEWON METAL

Substantiality Management

Quality Management

Customer Satisfaction



Head office / Factory 1

Juchon-myeon, Gimhae-si



Factory 2

Juchon-myeon, Gimhae-si



Factory 3

Jillye-myeon, Gimhae-si



25-54, Seobu-ro 1499beon-gil, Juchon-myeon, Gimhae-si, Gyeongsangnam-do

TEL 82-55-328-6401~3 / 82-55-338-6448~9 FAX 82-55-338-6450

HOMEPAGE www.sewonmt.com E-MAIL sw@sewonmt.com